

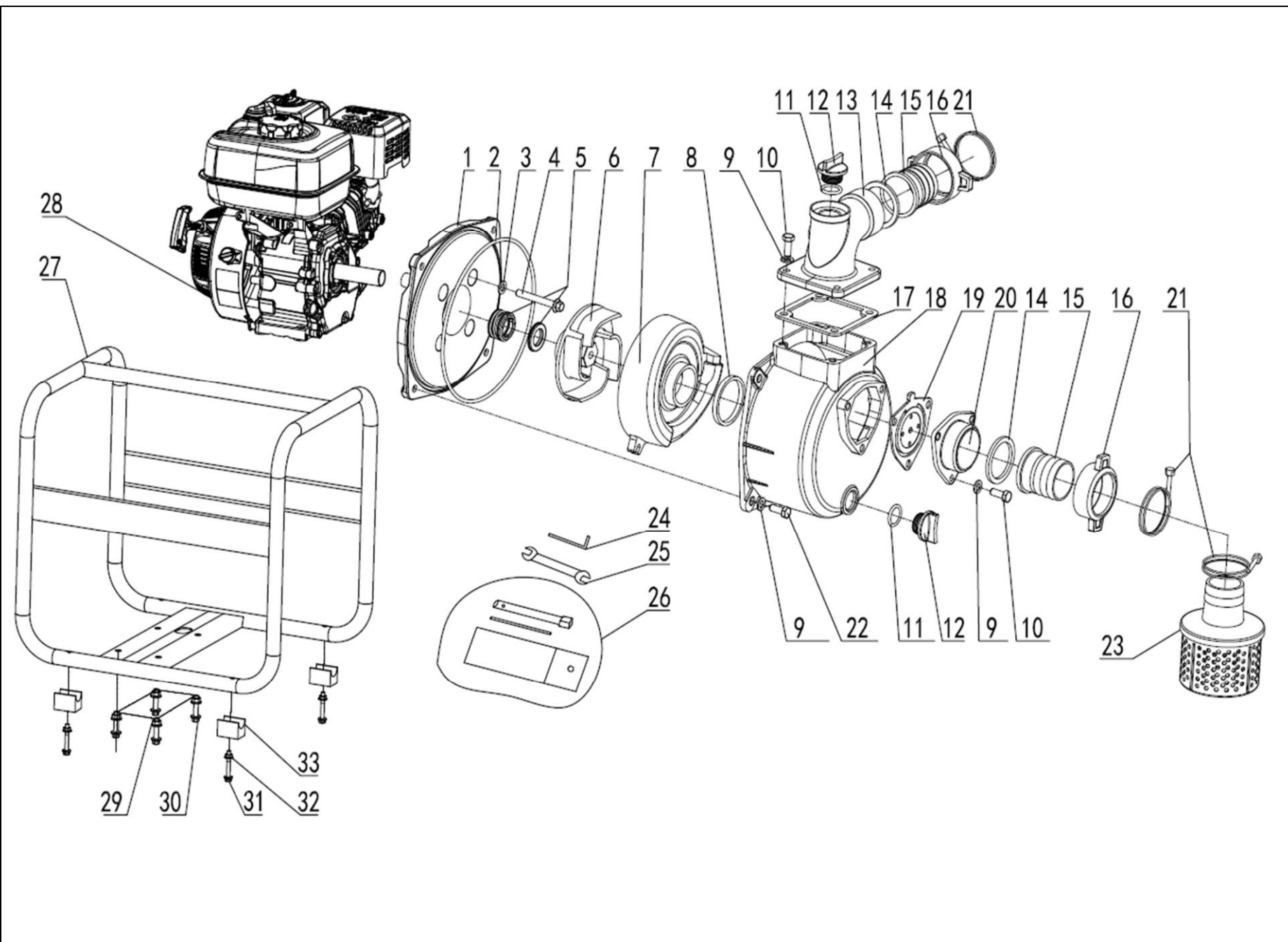

AMP Kohler Series 3-inch Semi-Trash Pump

AKWP30

Parts Schematics



NO.	Part NO.	Description
1	70010-00172-00	Pump Cover (Rear)
2	30152-00059-00	Large O ring (Pump Cover)
3	30136-00135-00	Aluminum gasket
4	30101-00468-00	Bolt
5	70010-00004-00	Mechanical seal
6	70010-00003-00	Impeller (Pump Assembly)
7	34037-00026-00	Volute (Diffusor)
8	30152-00069-00	O ring
9	30136-00126-00	Flat washer
10	30106-00002-00	Bolt
11	30152-00122-00	O ring
12	70010-00238-00	Prime Plug/Drain Plug
13	70010-01172-00	Outlet flange
14	33275-00015-00	Seal
15	33001-00028-00	Hose Barbs
16	70003-00851-00	Check valve
17	70010-00129-00	Inlet flange
18	39999-00413-00	Pump Housing Body (Front)
19	70010-00239-00	Inlet Check Valve Gasket

20	70010-01173-00	Suction Flange
21	34024-00044-00	Clamp
22	70010-00483-00	Bolt
23	34037-00010-00	Filter cover
24	70003-00858-00	Inner hexagon spanner
25	70003-00909-00	Open end wrench 8-10
27	20090-00033-00	Frame
28	20260-01587-00	Engine
29	30125-00003-00	Nut
30	30101-00461-00	Bolt
31	30114-00021-00	Hexagon socket pan head bolt
32	30128-00011-00	Nylon nut
33	34030-00066-00	Rubber Foot